

**Tender for Supply & Installation of 1000 nos. of  
Improved Woodbased Crematoria in the Gujarat  
(2017-18)**



**GEDA**

**Gujarat Energy Development Agency**

4<sup>th</sup> Floor, Block No.11-12, Udyog Bhavan,  
Sector-11, Gandhinagar – 382 017. (Gujarat)  
Ph : (079)2357251-54 Fax : 23257255  
E-mail : [info@geda.org.in](mailto:info@geda.org.in) Website: [www.geda.org.in](http://www.geda.org.in)

(Sign. & Seal of the Bidder)

## INDEX

<b>Sr. No.</b>	<b>Description</b>	<b>Page No.</b>
	<b><u>PART – I : TECHNICAL OFFER</u></b>	
<b>A</b>	<b>E Tender Notice</b>	<b>3</b>
<b>1</b>	<b>e Tendering (Online Tendering) Instruction to Bidders</b>	<b>4</b>
<b>2</b>	<b>Check List</b>	<b>6</b>
<b>3</b>	<b>General Information about the Bidder</b>	<b>7</b>
<b>4</b>	<b>Instructions to the Bidder</b>	<b>9</b>
<b>5</b>	<b>General Terms &amp; Conditions</b>	<b>12</b>
<b>6</b>	<b>Guidelines &amp; Specific Terms &amp; Conditions</b>	<b>15</b>
<b>7</b>	<b>Bid Evaluation Criteria</b>	<b>18</b>
<b>8</b>	<b>Technical Specifications &amp; Engineering Drawing</b>	<b>19-20</b>
<b>9</b>	<b>Manufacturing Capacity (Annexure – A)</b>	<b>21</b>
<b>10</b>	<b>Details of Similar Work Experience (Annexure – I)</b>	<b>22</b>
<b>11</b>	<b>Details of Man Power available for Execution of the Work (Annexure – II)</b>	<b>23</b>
<b>12</b>	<b>Declaration (Annexure – III)</b>	<b>24</b>
<b>13</b>	<b>Deviation Sheet (Annexure – IV)</b>	<b>25</b>
	<b><u>PART – II : PRICE OFFER</u></b>	<b>26</b>
<b>1</b>	<b>Schedule of Rates</b>	



## Gujarat Energy Development Agency

4<sup>th</sup> Floor, Block No.11-12, Udyog Bhavan,  
Sector-11, Gandhinagar – 382 017. (Gujarat)

Ph : (079)2357251-54 Fax : 23257255

E-mail : [ec@geda.org.in](mailto:ec@geda.org.in) Website: [www.geda.org.in](http://www.geda.org.in)

### A. E- TENDER NOTICE

Gujarat Energy Development Agency invites sealed offers for Supply & Installation of 1000 nos. of Improved Crematoria in the State of Gujarat during the year 2017-18. Tender Document can be downloaded from the Agencies website <https://geda.nprocure.com> or [www.nprocure.com](http://www.nprocure.com).

Interested parties are required to fill in the requisite details and submit their Technical Bid and Financial Bids along with a non-refundable Tender Fee of Rs. 3000/- and an EMD of Rs.3,00,000/- in the form of Demand Draft drawn on any Nationalized Bank, ICICI Bank, IDBI Bank, AXIS Bank, HDFC Bank, Kotak Mahindra Bank, Yes Bank, IndusInd Bank , Saurashtra Gramin Bank, Baroda Gujarat Gramin Bank, Dena Gujarat Gramin Bank, The Kalupur Commercial Co-operative Bank Ltd. , Rajkot Nagrik Sahakari Bank Ltd. , The Ahmedabad Mercantile Co-operative Bank Ltd., The Mehsana Urban Co-operative Bank Ltd. separately in favor of Gujarat Energy Development Agency payable at Gandhinagar.

The Tender schedule is as follows:

S.No.	Tender Schedule	Date	Time
1	Online Tender Downloading Starts	20 <sup>th</sup> April 2017	12:00 pm
2	Online Tender Downloading Ends	19 <sup>th</sup> May 2017	12:00 pm
3	Last Date for Physical submission in GEDA Office	20 <sup>th</sup> May 2017	03:00 pm
4	Bid Opening at GEDA Office	20 <sup>th</sup> May 2017	03:30 pm

Director, GEDA reserves the right to reject any/all offers without assigning any reasons thereof.

**Director**  
**Gujarat Energy Development Agency, Gandhinagar**

(Sign. & Seal of the Bidder)

## 1.0 E-TENDERING (ONLINE TENDERING) INSTRUCTIONS TO BIDDERS

<b>1.0</b>	<b>Down loading of Tender Documents</b>
1.1	Bid document will be available on web site up to date shown in the tender advertisement.
1.2	Bidders who wishes to participate in this tender will have to get themselves registered on web site <a href="http://www.nprocure.com">www.nprocure.com</a> or <a href="https://geda.nprocure.com">https://geda.nprocure.com</a>
<b>2.0</b>	<b>Digital Certificate</b>
2.1	Bidders who wish to participate in on line tenders will have to procure / should have legally valid digital Certificate as per Information Technology Act 2000 using which they can sign their electronic bids. Bidders can procure the same from any of the license certifying Authority of India or can contact (n) code solutions- a division of GNFC Ltd, who are licensed certifying Authority by Govt. Of India
2.2	All bids should be digitally signed, for details regarding digital signature certificate and related training involved the below mentioned address should be contacted
2.3	(n) Code Solution-A division of GNFC Ltd., (n) procure cell 403, GNFC Infotower, S. G. Road, Bodakdev, Ahmedabad- 380 054 Tel: +91 79 26854511/12/13 (Ext. 501,512, 516,517,525) Fax: +91 79 26857321 E-mail: <a href="mailto:nprocure@ncode.in">nprocure@ncode.in</a> Toll free number: 1-800-233-1010 (Ext. 501, 512,516, 517,525)
2.4	Bidders who already have a valid Digital certificate need not procure a new digital certificate.
<b>3.0</b>	<b>On line Submission of Technical and Price Bid</b>
3.1	Bidders can prepare and edit their offers number of times before tender submission date and time. After tender submission date and time, Bidders cannot edit their offer submitted in any case. No written or online request in this regard shall be granted.
3.2	Bidders shall submit their offer, i. e. Technical bid as well as Price bid in Electronic format on above mentioned website and date shown in the tender details after Digitally signing the same. Physical submission of PRICE BID will disqualify the Bidders.
3.3	Offers submitted without digitally signed will not be accepted.
3.4	Offers only in physical form will not be accepted in any case.
<b>4.0</b>	<b>Contacting Officer</b>
4.1	Further details / clarification , if any required, will be available from Director, GUJARAT ENERGY DEVELOPMENT AGENCY, 4th floor, Block No. 11 and 12 Udyog Bhavan, Sector -11 Gandhinagar, Gujarat, India Phone : +91-079-23257251, 23257252, 23257253, 23257254
4.2	In case Bidders needs any clarification /assistance or if training required for participating in online tender , they can contact at following office:
4.3	(n) Code Solution-A division of GNFC Ltd., (n) procure cell 403, GNFC Info Tower, S. G. Road, Bodakdev, Ahmedabad- 380 054 Tel: +91 79 26854511/12/13 (Ext. 501,512, 516,517,525) Fax: +91 79 26857321 E-mail: <a href="mailto:nprocure@ncode.in">nprocure@ncode.in</a> Toll free number: 1-800-233-1010 (Ext. 501, 512,516, 517,525)

(Sign. & Seal of the Bidder)

<b>5.0</b>	<b>General Instructions</b>
5.1	The fees paid for on line tender document will not be refunded under any circumstances.
5.2	EMD in the form specified in tender document only shall be accepted.
5.3	Tenders without Tender document fees, earnest money deposit (EMD) and which do not fulfil all or any of the condition or submitted in complete in any respect will be rejected.
5.4	Bidders approved either by the Central/ State Govt. or Central / State Govt. undertaking is not exempted by this Agency for paying EMD , SD etc.
5.5	Conditional tender shall not be accepted.
5.6	The Internet site address for E-Tender is <a href="http://www.nprocure.com">www.nprocure.com</a> or <a href="https://geda.nprocure.com">https://geda.nprocure.com</a>
5.7	The GEDA reserves the right to reject any or all the tenders or split the work between more than one Bidder without assigning any reason thereof.
5.8	<b>The attachments to the tender document shall be duly filed and page numbered, with an index, specifying the document attached and its page number(s).</b>

(Sign. & Seal of the Bidder)

**2.0 CHECK LIST**

To ensure that your Tender submitted to GEDA is complete in all respects, please go through the following checklist & tick mark for the enclosures attached with your Tender:

<b>Sr. No.</b>	<b>Description</b>	<b>Attached</b>	<b>Not Attached</b>
1	Tender Document Fee DD/Cheque No:_____ date:_____		
2	Earnest Money Deposit (EMD) in the prescribed form		
3	The original document duly signed & sealed on every page, as a confirmation of acceptance of the terms & conditions of the document.		
4	Details of similar work executed for any Government Department / Organization in last three years alongwith copies of the orders and certificates from the customers, their address phone/fax as per the Bid Evaluation Criteria and as per Annexure – I of the tender document		
5	Details of Manufacturing facilities alongwith the list of Plant & Machinery etc, required for fabrication of tendered item.		
6	Details of Technical staff available (Brief Biodata of Key Personnel to be given) as per Annexure – II of the tender document		
7	Confirmation of Crematoria Design & Technical Specifications specified by GEDA		
8	Declaration of the Bidder about any relatives working with GEDA as per Annexure – III of the tender document		
9	Deviation, if any, from the specifications, terms & conditions etc. (Annexure – IV)		
10	Confirmation of Validity Financial Offer for period of 12 months.		

(Sign. & Seal of the Bidder)

**3.0 GENERATION INFORMATION ABOUT THE BIDDER**

<b>1.</b>	Name of the Company	
<b>1a.</b>	Postal Address	
<b>1b.</b>	Telephone/Fax no	
<b>1c.</b>	e-mail address & URL	
<b>2</b>	Type of Company <i>(Attach Proof of Company Registration alongwith a copy of the Partnership Deed/ Article of Association and Memorandum of Understanding)</i>	Proprietorship/ Partnership/ Private Limited/ Public Limited
<b>3</b>	Name and Designation of the representative of the Bidder to whom all reference shall be made to expedite technical co-ordination.	
<b>4</b>	Details of EMD submitted	Amount : Rs. _____ Cheque No: _____ dated; _____ Bank Name: _____
<b>5.</b>	Factory Address	
<b>5a.</b>	Factory Telephone/Fax no	
<b>5b.</b>	Factory e-mail address	
<b>5c.</b>	Information on Manufacturing facilities for Casting & Fabrication Work	
<b>6.</b>	Financial capacity of the company/ firm <i>(Attach copies of I.T. Returns and Balance Sheets for last 3 years duly certified by the Chartered Accountant)</i>	
<b>7.</b>	Details of Technical Staff <i>(Please furnish information as per Enclosed Annexure II.)</i>	
<b>8.</b>	<i>Details of Workmen (Skilled/ semi-skilled/unskilled)</i>	

(Sign. & Seal of the Bidder)

<b>9.</b>	List of components manufactured by the company at their factory	
<b>10.</b>	List of components sourced from outside/ other agencies	
<b>11.</b>	<p>Details of previous work experience with GEDA, if any</p> <ul style="list-style-type: none"> <li>• Systems supplied/ installed under GEDA Scheme</li> <li>• Systems supplied/ installed without GEDA Scheme</li> </ul> <p><i>(Details be appended with the application)</i></p>	
<b>12.</b>	Company PAN No:	
<b>13.</b>	<p>Has the company/firm to pay arrear of IT? If yes upto what amount.</p> <p><i>(Attach a copy of the Latest Income Tax Return duly filed and endorsed by the Income Tax Deptt).</i></p>	
<b>14.</b>	Has any Govt. Dept./ Undertaking ever debarred the company/ firm from executing any work?	
<b>15</b>	GST /CST/ TIN Number (A copy be enclosed)	
<b>16</b>	SSI/ NSIC Registration, if any ( A copy be enclosed)	
	Reference of any other information attached by the company <i>(give details of attachment)</i>	
<b>17</b>	Has the company any relative, working in GEDA, if yes, state the name, designation & relationship.	

It is certified that the information provided is true to the best of my knowledge & belief. If the information is found to be concealed / suppressed / incorrect tender shall be liable to be rejected & Bidder shall be debarred for executing business with GEDA.

(Sign. & Seal of the Bidder)



#### **4.0 INSTRUCTIONS TO BIDDER**

- A.1** Offer should be submitted complete in all respects with all schedules, documents etc. of the tender document issued by GEDA. Physical Tender shall be received in GEDA office up to the date and time as mentioned in the tender form.
- A.2** GEDA reserves the rights to reject any or all the Tenders or accept any tender in total or in part or may divide the work among various Bidders, without assigning any reason thereof.
- A.3** Physical Tender should be accompanied with requisite Earnest Money Deposit (EMD). Any Offer not accompanied by Earnest Money Deposit (EMD) shall be disqualified and no further consideration shall be given to such Offer. Bidders may note that no relaxation in this regard shall be made. **Bidders having valid registration with SSI for the tendered item and are having valid registration with CSPO/NSIC/DGS&D will be exempted from depositing the EMD.** NSIC/ SSI registration for other than tendered item will not be taken in to consideration and in such case; Bidder will be required to submit requisite EMD with their offer.
- A.4** Earnest Money Deposit (EMD) of unsuccessful bidders shall be returned on finalization of the order. EMD of successful bidders will be retained as Security Deposit.
- A.5** Validity of the offer should be at least up to 31<sup>st</sup> March 2018. Without this validity the Offers shall be rejected.
- A.6** Before submission of the Offer, Bidders are required to make themselves fully conversant with the scope of the work, technical requirements and specifications, etc., so that no ambiguity arises on a latter date in this respect.
- A.7** All information in the Offer shall be in English. Information in any other language should be accompanied by its translation in English. Failure to comply with this may disqualify the Bidder.
- A.8** The Offer must contain the name, address of residence and places of business of the person or persons submitting the Offers and should be signed with seal by the Bidder(s) with his/their usual signature(s).
- A.9** If the Bidder finds discrepancies in, or omissions from the specifications or other documents or if he is in doubt as to their meaning, he should at once intimate GEDA and obtain clarification in writing prior to submitting his Offer.
- A.10** Any approach from the Bidder, his representative or his agent to influence the decision on the Offer, officially or otherwise, shall render the Offer liable to be summarily rejected.

(Sign. & Seal of the Bidder)

**A.11** Physical offer should be submitted in sealed envelopes super scribed with as ” **Installation of Improved Crematoria in the State of Gujarat during year 2017-18**”.All the papers of Tender documents duly signed should be submitted in the envelope. Requisite Earnest Money Deposit and Tender Document Fee in the form of Demand Draft drawn on a nationalized bank, ICICI Bank, IDBI Bank, AXIS Bank, HDFC Bank, Kotak Mahindra Bank, Yes Bank, IndusInd Bank , Saurashtra Gramin Bank, Baroda Gujarat Gramin Bank, Dena Gujarat Gramin Bank, The Kalapur Commercial Co-operative Bank Ltd. , Rajkot Nagrik Sahakari Bank Ltd. , The Ahmedabad Mercantile Co-operative Bank Ltd., The Mehsana Urban Co-operative Bank Ltd. pledged in the name of “Gujarat Energy Development Agency”, payable at Gandhinagar should be attached with this bid.

**A.12** The procedure of opening of the Offer shall be as under :

**A.12.1** Physical Tender / Offer shall be opened on the date and time mentioned in the Tender Notice on page no.3 at GEDA’s Office, Gandhinagar. In unforeseen circumstances, GEDA may at its discretion change the date and time of opening of the tender. Bidder can attend the opening of the tender if they so desire.

**A.12.2** Online tender of only those Bidders shall be opened who have submitted physical tender document alongwith the tender fee and EMD.

**A.13** Offers of only those firms or individuals, who are either themselves technically capable and sound for providing such services and who give satisfactory evidence of such experience shall only be considered.

The date and time for opening of the **online Financial Offers** shall be decided by GEDA and informed to the Bidder.

**A.14** Erases and other changes shall be initialed by the person/persons signing the Offer.

**A.15** Each page of the Offer document should be signed & stamped by the Bidder as a token of acceptance to terms and conditions mentioned herein.

**A.16** The general technical requirements mentioned are mainly for the guidance of the Bidder. These requirements are not intended to preclude ingenuity of designs or other improvements. If the Bidder proposes any deviation from these requirements those shall be considered provided they are necessary either to improve the utility, performance and efficiency or to secure over all economy. The Bidder shall give a separate list containing points of deviations in his offer from the specifications asked for.

**A.17** The Bidder shall declare the name of the employee of GEDA and his relationship with him in case any employee of GEDA is a relative of the Bidder.

(Sign. & Seal of the Bidder)

- A.18** In the event, the successful Bidder fails to sign the agreement with GEDA or accept the work order within specified time or withdraws his offer within the validity period or fails to accept the order for any reason whatsoever, then the earnest money deposited by the Bidder shall be forfeited by GEDA & the Bidder shall be debarred for 3 years.
- A.19** GEDA reserves the right to accept any offer based on its merits and GEDA is not bound to place the order with the party having submitted the lowest offer. Thus party merely on the ground that their financial offer is lowest, does not necessarily qualify them for receiving the order.
- A.20** GEDA, at its discretion, may award the work to more than one party.

## **5.0 GENERAL TERMS AND CONDITIONS**

B-1 In this deed of agreement/ Offer, unless the context otherwise requires:-

GEDA shall mean the Director or his representative of Gujarat Energy Development Agency, with Head Office at 4<sup>th</sup> Floor, Block No.11 & 12, Udyog Bhavan, Sector – 11, Gandhinagar – 382 017, and shall include his successors and assignees.

The Bidder shall mean the Manufacturer who's Offer shall be accepted by GEDA and shall include such Bidders heirs, legal representatives, successors and assignees.

B-2 The Bidder shall be deemed to have carefully examined all the papers, drawings, etc. attached in the contract. If he has any doubt as to the meaning of any portion of any condition/ specification, etc. he shall before signing the contract submit the particulars thereof to GEDA in order that such doubts are removed.

B-3 The work, shall be completed within the completion period as mentioned in the agreement, failing which penalty at the rate of 1 % per week subject to maximum of 10 % of agreement value shall be imposed. This excludes delay in the completion of the work due to unforeseen reasons beyond the control and without fault and negligence of the Bidder including (but not restricted to) act of God or public anomie action of Government in its sovereign capacity, floods, epidemics, strikes, lockouts, fires and accidents. In the event of any of the aforesaid contingencies GEDA may be promptly kept informed by the Bidder by Fax/Telex/Telegram followed by confirmation in writing with documentary proof within fifteen days of commencement and cessation of Force Majeur circumstances. Under such circumstances reasonable extension of time shall be granted by GEDA. Application for such extension must be made before the due date of completion of work as per agreement. GEDA, at its discretion, may cancel the contract, if the work is not completed within reasonable time granted. In the event of termination of the agreement, GEDA shall be at liberty to get the remaining part of the work done through any other agency/Bidder in the manner and on the terms it thinks proper. If the cost of executing the work as aforesaid shall exceed the balance due to the Bidder, and the Bidder fails to make good the deficiency, GEDA may recover it from the Bidder in any lawful manner.

B-4 The Bidder shall have to comply with all rules, regulations, laws and bylaws enforced by local and State Govt. and also the organisation in whose premises the work has to be done.

B-5 The Bidder shall not, without the consent in writing of GEDA, transfer, assign or sublet the work under this contract or any substantial part thereof to any other party.

(Sign. & Seal of the Bidder)

- B-6 If the Bidder neglects to execute the work with due diligence and expedition or refuses or neglect to comply with any reasonable orders within two days notice given in writing to the Bidder and if he fails to comply with the notice, then in such a case GEDA shall be at liberty to get the work or any part of it, executed through any other agency/Bidder in the manner and on the terms it thinks proper. If the cost of executing the work as aforesaid shall exceed the balance due to the Bidder, and the Bidder fails to make good the deficiency, GEDA may recover it from the Bidder in any lawful manner.
- B-7 GEDA shall have at all reasonable time access to the works being carried out by the Bidder under this contract. All the works shall be carried out by the Bidder to the satisfaction of GEDA.
- B-8 Any question, dispute or difference whatsoever arises between GEDA and Bidder, in connection with this agreement except as to matters, the decision for which has been specifically provided, either party may forthwith give to the other notice in writing of existence of such questions, dispute, difference and the same shall be referred to the sole arbitration of a person nominated by Director GEDA. This reference shall be governed by Indian Arbitration Act prevailing at the time of dispute and the rules made there under. The award in such arbitration shall be final and binding on all the parties. Work under the agreement shall continue during the arbitration proceedings unless the GEDA or the Arbitrator directs otherwise.
- B-9 GEDA may at any time by notice in writing to the Bidder either stop the work altogether or reduce or cut it down. If the work is stopped altogether, the Bidder shall only be paid for work done and expenses legitimately incurred by him as on preparation of the execution of the work up to the date on which such notice is received by him. Such expenses shall be assessed by GEDA whose decision shall be final and binding on the Bidder. If the work is cut down the Bidder shall not be paid for the work as so cut down, but in neither case shall be paid any compensation what so ever for the loss or profit which he might have made if he had been allowed to complete all the work included in the contract.
- B-10 Prior to dispatch, the materials may be inspected and tested by GEDA at the Bidder's works. Bidder shall inform GEDA for such inspection at least 7 days in advance before the probable date of dispatch.
- B-11 The system supplied or installed shall be guaranteed by the Bidder for a minimum period of two years in regard to quality of material, workmanship, performance, efficiency, installation, etc. Defects developed in the system within guarantee period, shall be rectified by the Bidder at his own expense promptly. In case the defects are not rectified within 2 days of the receipt of the complaint by the Bidder, GEDA shall have full liberty to remove such defect or undertake such repairs as may be necessary to restore the system in working condition. The expenditure so incurred by GEDA shall be deducted from Bidder's pending claims, security, etc. and if necessary may be recovered in other mode

(Sign. & Seal of the Bidder)

provided under the law. In the event of failure of the complete system, if necessary, the whole system shall be replaced by the Bidder promptly.

- B-12 Notices, Statements and other communications sent by GEDA through registered post or telegram or telex or to the Bidder at his specified address shall be deemed to have been delivered to the Bidder.
- B-13 The work shall be carried out by the Bidder with prior approval of GEDA. Work carried out without GEDA's approval shall not be accepted and the GEDA shall have right to reject it and to recover the cost as so incurred, from the Bidder.
- B-14 All equipment/material shall be suitably packed for transport/carriage at site and outdoor storage during transit. The Bidder shall be responsible for any damage to the equipment during transit due to improper or inadequate packing. The cases containing easily damageable material shall be very carefully packed and marked with appropriate caution symbols i.e. 'FRAGILE, HANDLE WITH CARE' etc. The contents of each package shall bear marking that can be readily identified from the package list and packing shall provide complete protection from moisture, termites and mechanical shocks during shipment/transportation to site. Adequate protection must be provided for outdoor storage at site in tropical humid climate, wherever necessary proper arrangement for attaching signs for lifting shall be provided and all packages clearly marked with gross weight, signs showing 'UP' and 'DOWN' sides of boxes, contents of each package, order no. And date, name of the plant/equipments to which the material in the package forms the part of, and any handling and unpacking instructions considered necessary. The Bidder without any extra cost shall supply any material found short inside intact packing case. The Bidder shall ascertain prior to shipment, from concerned authorities, the transport limitations like weight and maximum allowable package size for transportation. All packing cases and packing material shall become the property of the purchaser.
- B-15 The Bidder shall provide one copy of the Instruction Manual on proper Operation & Maintenance in Gujarati with each item supplied. These manuals should contain sketch of the tendered item with labeling of each component giving its size & quantity which may be require in case of replacement of damaged component.
- B-16 The Bidder shall not involve in publicity of the work without written permission from GEDA.
- B-17 The inspection as mentioned in clause No. B-10 by GEDA's representative shall not relieve the Bidder from full responsibility of completing the work confirming to the requirement of this contract.
- B-18 Conditional tender cannot be accepted.

(Sign. & Seal of the Bidder)

## **6.0 GUIDELINES AND SPECIFIC TERMS & CONDITIONS**

1. Offers are invited for Supply & Installation of Improved Crematoria at any site in the State of Gujarat. The minimum number of improved crematoria to be supplied & installed within the State under this tender will be 200 nos. However, GEDA, at its discretion may increase/decrease the quantity.
2. GEDA, at its discretion, may allocate quantity to more than one Bidder and will decide the quantity to be allocated to them. Decision of GEDA in this matter, will be binding to all the Bidders.
3. The Bidder should either have their own foundry or have a tie-up arrangement with another foundry to manufacture and supply ordered quantity of Improved Crematoria. Documentary evidences in support of such tie-up should be submitted in original with the offer. The Bidder should clearly give information on manufacturing capacity of their own foundry or that of the company with whom they have tie-up. GEDA may visit manufacturing facilities of the Bidder as well as their tie-up partner to ascertain the claims made by the Bidder.
4. Offers received from Bidders, whose Earnest Money Deposit/ Security Deposit has been forfeited by GEDA in last three years or those Bidders who have failed to supply Improved Crematoria as per the order in the past, will not be taken in to any consideration.
5. Successful Bidders will be required to deposit security deposit @ 5% of total value of the work awarded to them. The Security Deposit will be accepted in the form of Demand Draft drawn on a nationalized bank, ICICI Bank, IDBI Bank, AXIS Bank, HDFC Bank, Kotak Mahindra Bank, Yes Bank, IndusInd Bank , Saurashtra Gramin Bank, Baroda Gujarat Gramin Bank, Dena Gujarat Gramin Bank, The Kalupur Commercial Co-operative Bank Ltd. , Rajkot Nagrik Sahakari Bank Ltd. , The Ahmedabad Mercantile Co-operative Bank Ltd., The Mehsana Urban Co-operative Bank Ltd. pledged in the name of "Gujarat Energy Development Agency", payable at Gandhinagar. The Security Deposit can also be submitted in the form of Bank Guarantee issued by Schedules Bank as per GEDA's format. Or the EMD of the successful bidders could also be retained as part of SD required to be deposited by the successful bidder.
6. In the event of granting additional targets, the Supplier will be required to deposit additional Security Deposit on prorata basis within one week of the issuance of LOI for the additional target.
7. It is mandatory for the Supplier to achieve targets allocated to them in all the areas of the state – including the Tribal Areas.
8. It is essential for qualified bidders to supply & also install allotted number of systems before timelines decided by this Agency. To ascertain the manufacturing capabilities of each Supplier, no. of systems that could be supplied, installed and commissioned by the Supplier in the state, every Supplier is required to submit with their technical offer, information about manufacturing capacity of their factory and no. of systems that could be supplied in the State under agreement with GEDA as per the Annexure – A. In the event of failure to supply no. of systems as committed by the Supplier as per Annexure – A as accepted by them while receiving the authorization, will lead to forfeiture of the Security

(Sign. & Seal of the Bidder)

Deposit up to 100% and will lead to disqualification of the Supplier for transacting business with GEDA for at least two years or the time duration as may be decided by the Director, GEDA.

9. Each manufacturer will be required to deliver assemble and install systems proportionately within the agreed duration. The no. of crematoria supplied and installed will be reviewed periodically and if the progress is not found to be satisfactory, Director, GEDA reserves the right to reduce the quantity to any extent.
10. In case of any type of misappropriations, cheating or intention of cheating, frauds, irregularities, malpractice, etc. the Director GEDA reserves the right to cancel the authorisation without giving reasons thereof and forfeit the security deposit.

**11. DELIVERY SCHEDULE:**

The IMPROVED CREMATORIA is to be supplied directly at site **ANYWHERE in Gujarat State**. The name of the beneficiaries/sites shall be intimated by GEDA from time to time. As far as possible, GEDA will intimate to the Bidder with the list of beneficiaries/ sites in a minimum lot of 50 nos. Since, timely completion of work is essence of the project; Bidder will be required to arrange for manufacturing and supply of goods to respective sites within 15 days from the date of receipt of list of sites from GEDA.

**12. INSPECTION OF GOODS**

Prior to dispatch, the materials shall be offered for inspection to GEDA / GEDA's authorized Third Party Inspection Agency at the Bidders' works. Bidder shall inform GEDA/ GEDA's authorized Third Inspection Agency in writing for such inspection at least 10 days in advance before the probable date of dispatch. The factory inspection of Improved Crematoria shall be offered for lots not less than 50 nos.

On-site inspection of crematoria supplied and installed will be carried out by GEDA / GEDA's authorized Third Party Inspection Agency as per norms of GEDA.

**13. WARRANTY**

The system supplied shall be warranted by the Bidder for a minimum period of one year in regard to quality of material, workmanship, faulty installation, etc. The Bidder shall rectify defects developed in the system within warrantee period promptly. In case the Bidder does not rectify the defects within 10 days of the receipt of the complaint, GEDA shall have full liberty to remove such defects or undertake such repairs as may be necessary to restore the system in working condition. The expenditure so incurred by GEDA shall be deducted from Bidder pending claims security, etc. and if necessary may be recovered in other mode provided under the law.

**14. PACKING & FORWARDING**

All equipment/material shall be suitably packed for transport/carriage at site and outdoor storage during transit. The supplier/ Bidder shall be responsible for any damage to the equipment during transit due to improper or inadequate packing. The Bidder shall provide

(Sign. & Seal of the Bidder)



list of packing to consignee alongwith the goods indicating name of component/s, quantity (nos.), material approximate weight of component/s etc.

Transportation of goods to sites has to be arranged by the Supplier. All packing cases and packing material shall become the property of the purchaser. The detailed dispatch instructions including name of consignee will be intimated to the successful Bidder. The Bidder shall intimate, at least 15 days in advance to the consignee the probable date when the goods are ready for dispatch. The telegraphic intimation shall also be given to the consignee immediately after the dispatch of the equipment mentioning the dispatch number, order number, date of dispatch, and number of package, wagon number and approximate weight of each package. The Bidder should arrange to take delivery and unload the material. Any demurrage incurred due to noncompliance of the above instructions shall be to the Bidder account. Bills duly pre receipted in triplicate in accordance with approved terms of payment and together with all necessary dispatch documents shall be sent to the Director of GEDA.

**15. PAYMENT TERMS:**

The payment terms shall be as follows:

- a. 30 % of total order value shall be paid as an advance to the Bidder against submission of bank guarantee of equivalent amount issued by Nationalized Bank as per the prescribed format of GEDA.
- b. 60 % total order value shall be released to the Bidder after submission of following necessary documents **in duplicate** at GEDA & after on-site verification/ inspection by GEDA and/or its authorised inspection agency/ies as per norms of GEDA, for which the claim is received:
  - Bills
  - Installation certificate duly signed by beneficiary or his/her representative showing its installation date.
- c. 10% of the order value against submission of Performance Bank Guarantee (drawn on Nationalized Bank, as per the prescribed format of GEDA) of equivalent amount, valid for a period of one year from the date of Installation of the Crematoria.
- d. Security Deposit shall be released with 90% payment of the order value.

16. Rates quoted by Bidder will be inclusive of taxes, levies, duties, packing, forwarding, freight, insurance, loading unloading, supply, assemble, installation, commissioning, and any/ all charges for successful Supply & Installation of the Improved Crematoria at any locations in the State of Gujarat.

17. The rates quoted by the Bidder will be inclusive of Service Tax, Work Contract Tax, VAT or any other taxes applicable to such work. Any escalation in such taxes/ levies during the tenure of the contract/ order, will not be paid by GEDA and Bidders are advised to take in to consideration any such escalations in the prevailing taxes/levies/duties.

(Sign. & Seal of the Bidder)

## **7.0 BID EVALUATION CRITERIA**

Tenders are invited from manufacturers having adequate infrastructure facilities for manufacturing, Supply & Installation of Improved Crematoria and satisfying criterion as per the following Bid Evaluation Criteria (BEC). Offers of only those parties who are found qualifying based of following Offer Evaluation Criteria will be taken in to further consideration and prices of only those parties qualifying based of these criterion will be opened.

### **COMMERCIAL**

1. Earnest Money Deposit shall have to be submitted along with physical tender copy before specified timeline.

### **TECHNICAL**

1. Offers received from only those parties having adequate infrastructure to manufacture, Supply & Install Improved Crematoria in the state will be taken in to consideration and offers received from others will be summarily rejected.
2. Documentary evidence in support of Bidder's claim for having their own foundry or having appropriate tie-up with another foundry, as the case may be. Documentary evidences in support of such tie-up should be submitted in original with the offer.
3. The Bidder should clearly give information on manufacturing capacity per month of their own foundry or that of the company with whom they have tie-up. GEDA may visit manufacturing facilities of the Bidder as well as their tie-up partner to ascertain the claims made by the Bidder.
4. The party should have executed atleast one casting & fabrication work of minimum value of Rs 25 lakhs in last three financial years i.e. 2014-15, 2015-16 & 2016-17.
5. Details of similar work done in last three years alongwith copies of the orders and certificates from the user agencies should be submitted alongwith the Technical Offer as per Annexure – I of the Offer Document.
6. The party should have sufficient technically qualified and well-experienced manpower for Manufacturing & Installation of Improved Crematoria. Brief biodata of the key personnel be enclosed with the offers as per Annexure-II of the Document.

### **GENERAL**

1. The party should declare if they have any relatives working with GEDA as per Annexure –III.
2. As an acceptance of terms and conditions, the document duly signed and sealed on every page should be returned along with the offer.

**Offers not satisfying any of the above mentioned criteria will be liable for rejection.**

(Sign. & Seal of the Bidder)

### **8.0 TECHNICAL SPECIFICATIONS & ENGINEERING DRAWING**

The Improved crematoria shall comprise of a cast iron bed and cast iron side brackets. The bed and side brackets shall be fixed by nuts and bolts in MS angles. The detailed engineering drawing for fabrication of improved crematoria is enclosed with this document. The total weight of improved crematoria shall not be less than 520 kgs.

The dimension of all the components of the Improved Crematoria would be as per the design drawing furnished by GEDA. Component-wise specification would be as per the details mentioned in the table below:

No.	Component	Material	Quantity (nos.)	Dimension (in mm)	Component Weight (in kgs.)	Total weight (in kg)
1	Lower Bracket (Item no 1 Fire Bars)	Cast Iron	8	as per drawing	22	176
2	BTM Supp Angle (Item no 2 side angle)	Cast Iron	2	as per drawing	33	66
3	Side Angle (Item no 3)	Cast Iron	4	as per drawing	15	60
4	Middle Angle (Item No 4)	Cast Iron	2	as per drawing	25	50
5	Side Brackets (Item no 5)	Cast Iron	12	as per drawing	13	156
6	Hex Bolts & Nuts (Item no 6 & 9)	MS (as per BIS)	32	M12 X 70	12	12
7	Hex Nuts & Bolts (Item no 7 & 9)	MS (as per BIS)	48	M12 X 90		
8	Plain Washers (Item no 8)	MS (as per BIS)	80	M12		
Approximate Total Weight					520 kg	520

Bidders will mention the weight of individual items mentioned above.

- Composition of Casting and its Test Report should be submitted alongwith Technical Bid.
- All components will be properly chipped, fine ground and painted with red-oxide
- Holes will be provided as per specifications on all the components.
- All bolts & nuts, as per specifications, will be checked and packed properly.
- "Serial Numbers, Year and GEDA" will be neatly embossed on atleast one vertical support in each set. (middle angle item no 4 of drawing) outer side in each set
- List of items delivered, at each site, will be provided to the consignee at the time of delivery.
- Installation / assembly of the crematoria would be done at the site.

(Sign. & Seal of the Bidder)

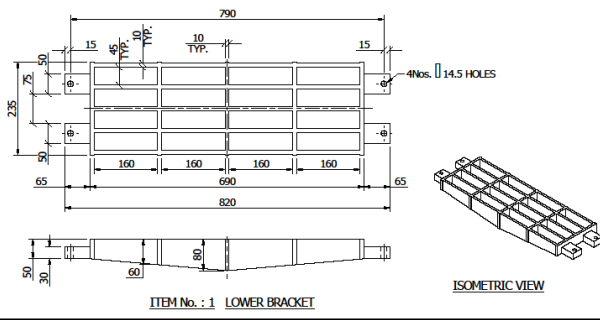
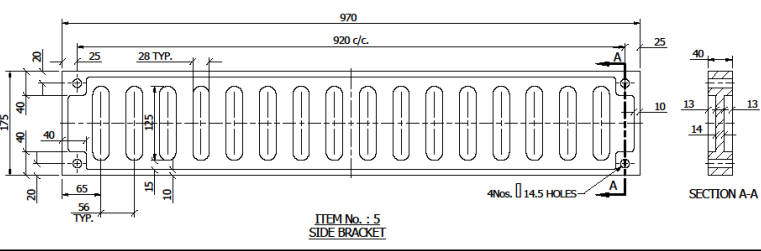
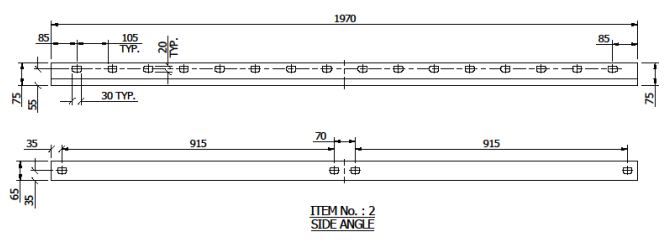
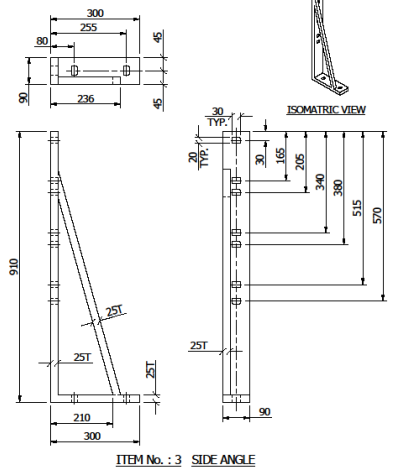
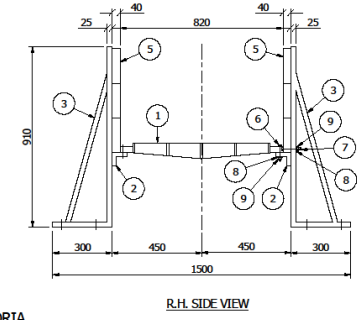
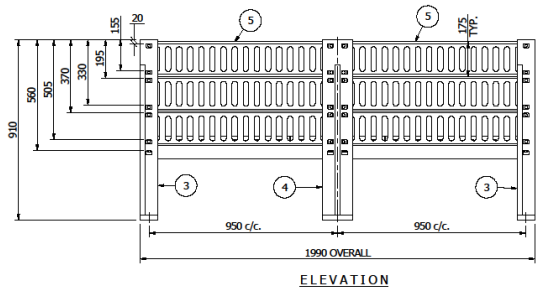
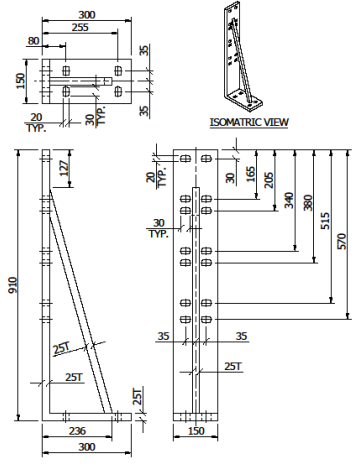
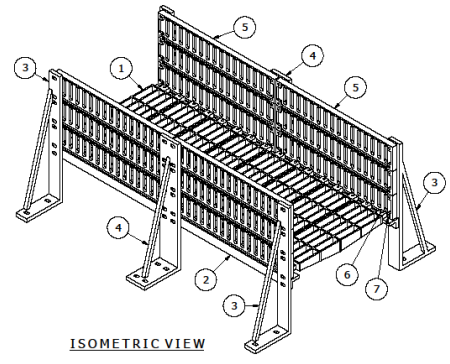
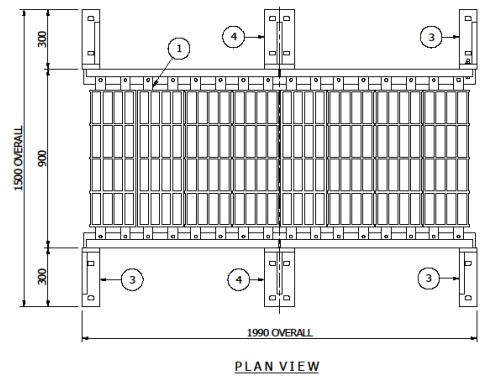

GENERAL NOTES :-  
1) ALL DIMENSIONS ARE IN mm, UNLESS OTHERWISE SPECIFIED.  
2) UNSPECIFIED CASTING RADIUS SHOULD BE Min. R<sub>6</sub>.

PARTS LIST				
ITEM	QTY	PART NUMBER	DESCRIPTION	MATERIAL
1	8	LOWER BRACKET	820 x 235 x AS PER DET.	Iron, Cast
2	2	BTM SUPP ANGLE	UNI-EQ. ANGLE L 75 x 65 x 20T x 1970 Lg. x AS PER DET.	Iron, Cast
3	4	SIDE ANGLE	AS PER DETAIL	Iron, Cast
4	2	MIDDLE ANGLE	AS PER DETAIL	Iron, Cast
5	12	SIDE BRACKET	40T x 175 x 970 x AS PER DET.	Iron, Cast
6	32	M12 x 70	Hex Bolt	Steel, Mild, AS PER BES
7	48	M12 x 90	Hex Bolt	Steel, Mild, AS PER BES
8	160	M12	Metric Plain Washers	Steel, Mild, AS PER BES
9	80	M12	Hex Nut	Steel, Mild, AS PER BES

IMPROVED CREMATORIA  
ENGINEERING DRAWING

**Annexure - A**

**9.0 MANUFACTURING CAPACITY**

<b>Name of the Bidder</b>	
<b>Address of the Manufacturing Facility/ their own foundry</b>	
<b>Name of the Foundry, with whom the Bidder is having tie-up arrangement</b>	
<b>Address of the tie-up partner</b>	

<b>Sr. No.</b>	<b>Item</b>	<b>Manufacturing Capacity per month Nos</b>	<b>No. of Improved Crematoria supplied, installed &amp; commissioned in the State so far</b>
<b>1</b>	<b>Improved Crematoria</b>		

<b>Name of the Authorised Signatory:</b>	
<b>Signature of the Authorised Signatory:</b>	
<b>Seal of the Company :</b>	

(Sign. & Seal of the Bidder)

**Annexure – I**

**Details of similar work experience in last three years**  
*(Information to be attached with the Technical Offer)*

<b>Sr. No.</b>	<b>Name of the Company with full address, phone, fax and name of contact person</b>	<b>Work Description</b>	<b>Ref. &amp; date of the order</b>	<b>Work Order Value</b>	<b>Details of order &amp; its configuration</b>

- Copies of Work orders alongwith Work completion certificates should be attached with this information.
  - If necessary, separate sheet may be used to submit the information.

(Sign. & Seal of the Bidder)

**Annexure – II**

**Details of Technical staff available with the company for execution of work**  
*(Information to be attached with the Technical Offer)*

<b>Sr. No.</b>	<b>Name</b>	<b>Qualification</b>	<b>Additional Certification, if any</b>	<b>Total Experience, no. of years</b>	<b>Remarks</b>

- Copies of Resumes and appropriate certifications should be attached with this information.
  - If necessary, separate sheet may be used to submit the information.

(Sign. & Seal of the Bidder)

**ANNEXURE – III**

**DECLARATION**

***(Strike off whichever is not applicable)***

This is to declare that Mr/Ms. \_\_\_\_\_, employee of GEDA  
at \_\_\_\_\_(place), is related to our \_\_\_\_\_  
\_\_\_\_\_(designation & name).

OR

This is to declare that none of the Proprietors/ Partners/ Directors are having any relatives employed or working with Gujarat Energy Development Agency at any of its offices or its parent Department i.e. Energy & Petrochemicals Dept., Govt. of Gujarat.

Date :

**Sign. & Stamp of the Bidder**

(Sign. & Seal of the Bidder)



**Annexure - IV**

**DEVIATION SHEET**

Any deviations offered from the terms and conditions of the Offer should be clearly specified below in this sheet. If there are no deviations offered, it should be clearly mentioned on this page.

<b>Deviation offered to Chapter No, Clause No. of the tender document</b>	<b>Deviation offered</b>

(Sign. & Seal of the Bidder)

**PART - II**

**PRICE OFFER (To be filled in “e-tender only”)**

Rates quoted by Bidder will be FOR destination prices inclusive of all types of govt. taxes, levies, duties, packing & forwarding, freight, insurance, loading unloading, supply and installation of the Improved Crematoria at any locations in the State of Gujarat.

- Under no circumstances, escalation in the rate offered will be entertained.
- Financial Offer is to be submitted as per the enclosed proforma of Schedule of Rates.
- Sales Tax forms 'C' or 'D' shall not be given by GEDA to the Bidder.
- No octroi exemption certificate shall be given by GEDA to the Bidder.
- No revision in excise duty rates shall be considered after placement of orders.

**SCHEDULE OF RATES**

<b>Name and address of Bidder</b>	
-----------------------------------	--

<b>Sr. No.</b>	<b>Item</b>	<b>Approx. Qty.</b>	<b>Rate Rs.</b>	<b>Total Amount, Rs.</b>
1	Rate for Supply & Installation of Improved Crematoria – as per GEDA specified design, anywhere in the Gujarat – all inclusive in accordance with terms and conditions of tender	1000 Nos		

(Sign. & Seal of the Bidder)